

Magnetic Base Drills

HOLEMAKER PRO 110

#4 MORSE TAPER

VARIABLE SPEED MACHINE



The Holemaker PRO 110 is an extra heavy duty, large capacity machine capable of producing burr-free holes up to 110mm diameter by 110mm depth. 1650w motor with 4-speed mechanical gearbox produces superb torque through gear reduction in low speeds. #4 morse taper spindle bore for use with taper shank drills, tapping head (M30 Capacity) and taper shank reamers.

Supplied complete with side mounted coolant system and arbor for use with 3/4" shank Holemaker Cutters up to 75mm diameter and 75mm depth of cut. Optional arbor to take 1-1/4" shank cutters up to 110mm diameter and 110mm depth. 1L pressure feed coolant bottle available, recommended for use with large diameter and depth hole drilling.



Part No.	HMPRO110
Capacity (Diameter)	110mm
Capacity (Depth)	110mm
Capacity (Twist Drill)	#4 Morse Taper 47mm
Motor Power	1650Watt
Input Power	1800Watt Single Phase 240V
Gearbox	4 Speed Heavy Duty Mechanical Gearbox 85 / 135 / 160 / 250rpm
Weight	31.0kg
Magnetic Dead Lift	22000N-m on 25mm Steel Plate
Stroke	230mm
Height (min / max)	566mm / 780mm
Through Spindle Coolant System	
Smart Magnet Technology to ensure sufficient Magnetic Adhesion	
Supplied In Metal Carry Case with Cutter Guard & Safety Strap	

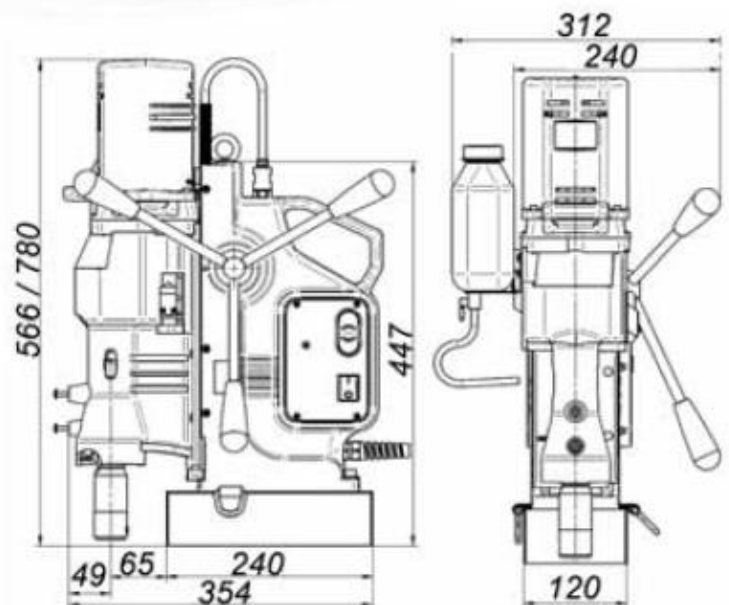

Optional Accessories & Consumables



Holemaker Cutters



#4 Morse Taper Drill Bits

Up to 47mm diameter



Twist Drill Chuck

Complete setup to adapt your Holemaker Machine to use twist drill bits.